

Specifications

Frequency:	433.39 MHz
Security:	128-bit AES encryption
Range:	up to 30 metres
Battery life:	up to 10 years
Battery type:	14500 mA battery



Wireless Vehicle Detection System

EL00IG and EL00IG-RAD

Installation in 3 simple steps

STEP 1:

Coding e-LOOP into e-Trans 50

Coding e-LOOP without magnet

1. Power up the **e-TRANS-50** and hold the e-Loop within 10cm of the transceiver's antenna.
2. Now press and release the CODE button on the e-Trans 50. The yellow and red LEDs will flash on the e-Loop, and the blue LED on the **e-TRANS-50** will flash 3 times. The systems are now paired.

NOTE: For coding **e-TRANS-200** LCD transceivers, refer to **e-TRANS-200** manual.

Coding e-LOOP with magnet

1. Power up the **e-TRANS-50**, then press and release the CODE button. The blue LED on the **e-TRANS-50** will light up.
2. Now place the magnet on the CODE recess on the e-Loop – the yellow LED will flash 3 times, and the blue LED on the e-Trans 50 will flash 3 times. The systems are now paired and you can remove the magnet.

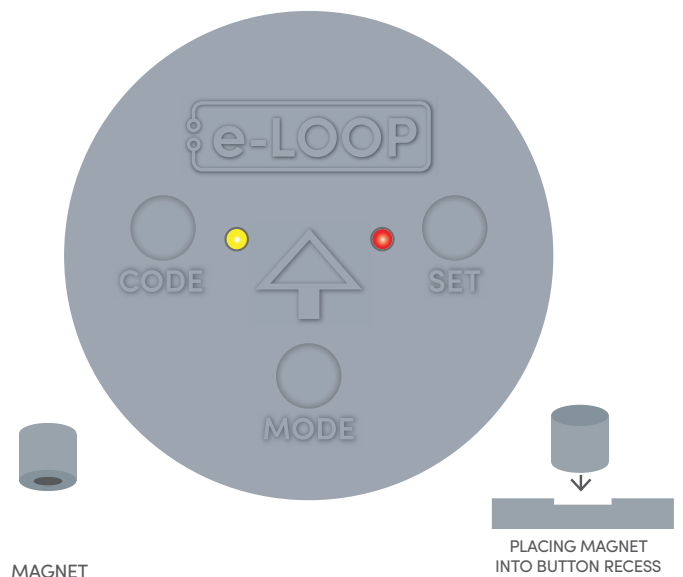

Changing mode using magnet (EL00IG-RAD Only)

Note: e-loop comes preset in presence mode.

1. Place a magnet on the MODE recess. The yellow LED will flash indicating presence mode.
2. Place a magnet on the SET recess for exit mode, or the CODE recess to change back to presence mode.
3. The LED will flash red for exit mode or yellow for presence mode.
4. Wait 5 seconds and the e-loop will automatically exit the menu.

STEP 2: Fitting e-LOOP

(Refer to diagram below)

1. Drill a 89-92mm hole, 65-70mm deep. Ensure hole is clean and dry before fitting.
2. Measure down before inserting the e-LOOP to ensure it will fit flush with the driveway surface, then pour sikaflex or similar compound into the base of hole.
3. Insert the e-LOOP by pushing down until flush or slightly above the driveway surface. (Never push below the driveway surface)

NOTE: Ensure e-LOOP is fitted in a well drained area, as water over the e-LOOP can effect the radar detection system.

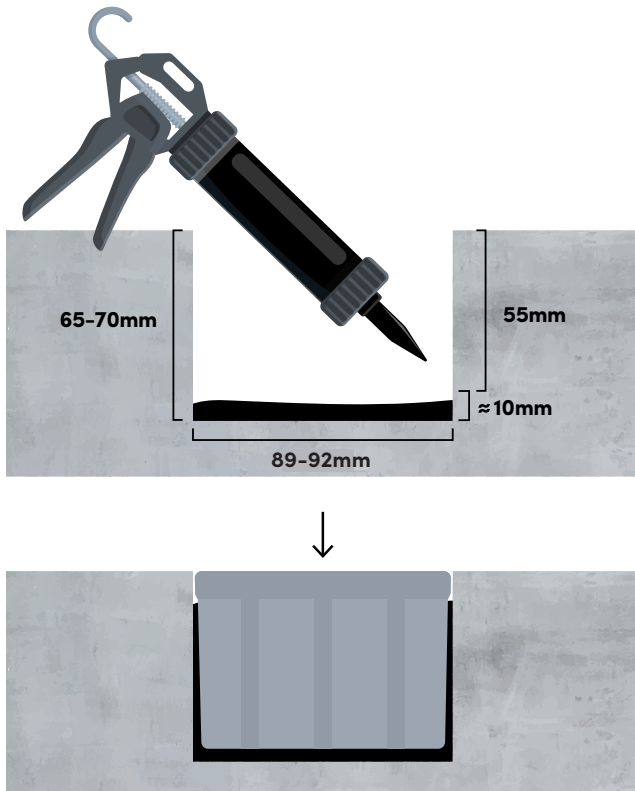

STEP 3: Calibrate e-LOOP

1. Move any metal objects away from the e-LOOP.
2. Place magnet into the SET button recess on the e-LOOP until the red LED flashes twice, then remove the magnet.
3. The e-LOOP will take about 5 seconds to calibrate and once complete, the red LED will flash 3 times.

System is now ready.

NOTE: After calibration you may get an error indication.

ERROR 1: Low radio range – yellow LED flashes 3 times before red LED flashes 3 times.

ERROR 2: No radio connection – yellow and red LED flashes 3 times before red LED flashes 3 times.

Uncalibrate e-LOOP

1. Place magnet into the SET button recess until red LED flashes 4 times, e-LOOP is now uncalibrated.

Changing mode

You can change the mode by using the **e-TRANS-200** LCD transceiver or diagnostic remote ED00R – refer to manual.

NOTE: This menu cannot be accessed via the **e-TRANS-50** Transceiver.

The e-LOOP EL00IG is set to EXIT mode (this can't be changed).

Parameters that can be altered:

- 1) Activation detection level
- 2) X, Y, Z axis sensitivity

Parameters that can be altered on EL00IG-RAD:

- 1) Mode is set to PRESENCE but can be changed to EXIT mode. **NOTE:** do not use presence mode as a personal safety device.
- 2) Activation detection level
- 3) X, Y, Z axis sensitivity
- 4) Radar read time
- 5) Release trip point
- 6) Start lens detection range
- 7) Measure lens detection range
- 8) Radar trip sensitivity
- 9) Radar confirm ON/OFF