



Automation Systems

A U S T R A L I A

ORION_{LS}

24 Volt Telescopic COMPACT
Linear Actuator System
With Limit Stops



Pull To Open Installation (Gate opens TOWARDS the motor) begins Page 4
Push To Open Installation (Gate opens AWAY from the motor) begins Page 7

Important!

Please read the manual carefully as it contains important points that need to be followed for a successful installation, we recommend reading all the preliminary information FIRST (page 1-3) then proceed to the relevant installation section and read in its entirety at least once before beginning the installation.

Specifications

Voltage	24V DC
Current	2.5A
Thrust	1200N
Case Material	Die Cast Alloy and Aluminium Extrusion
Piston Material	Stainless Steel with Alloy End Adapter
Duty Cycle	60%
Working Temperature	-20°C to 60°C
IP Rating	IP 54
Min. Length	850mm
Max. Length	1250mm
Stroke	510mm (One Limit stop removed) 440mm (Between Limit Stops)
Minimum Gate Length	1000mm
Maximum Gate Length	4200mm (Farm Gate)

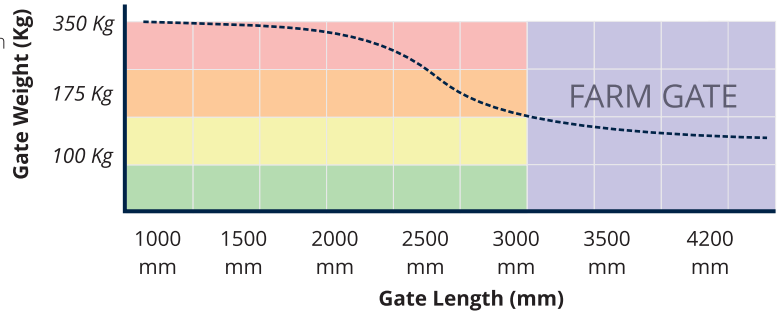

*Tested ratings are based on ball bearing hinges and no wind resistance

Dimensions & Stroke

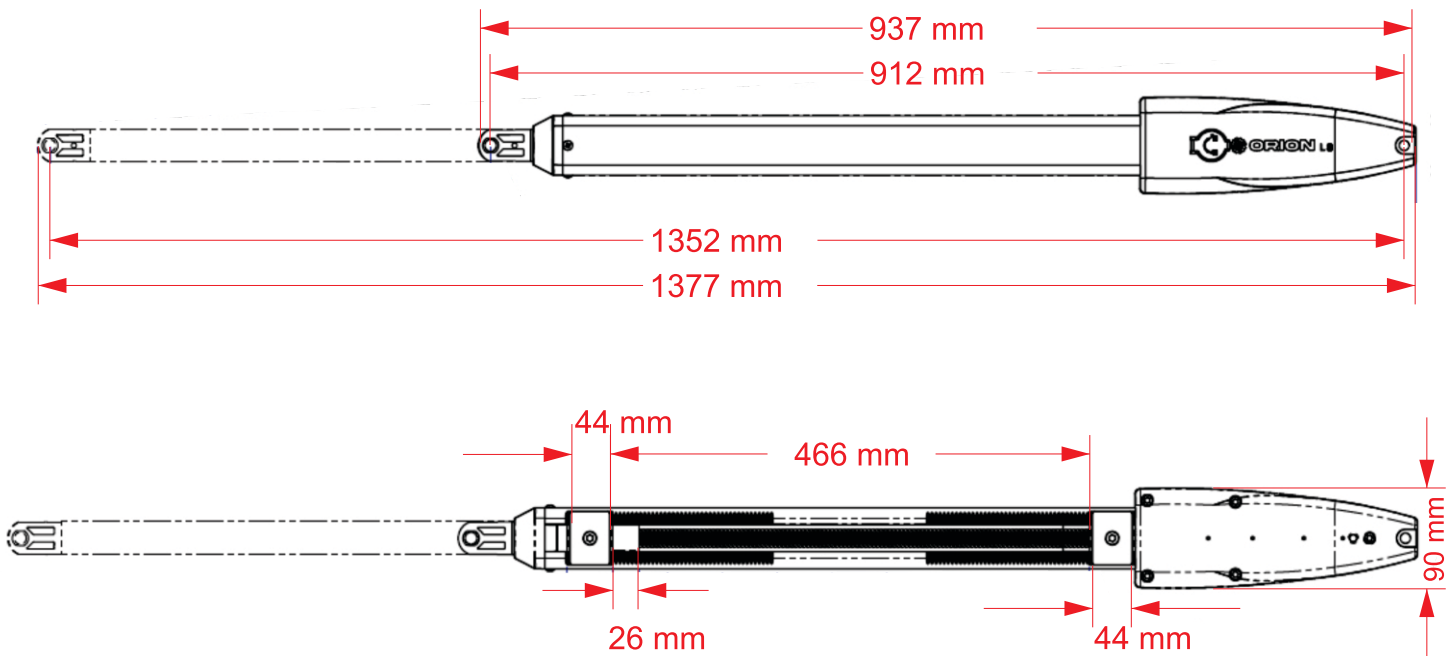

Manual Release (Clutch)

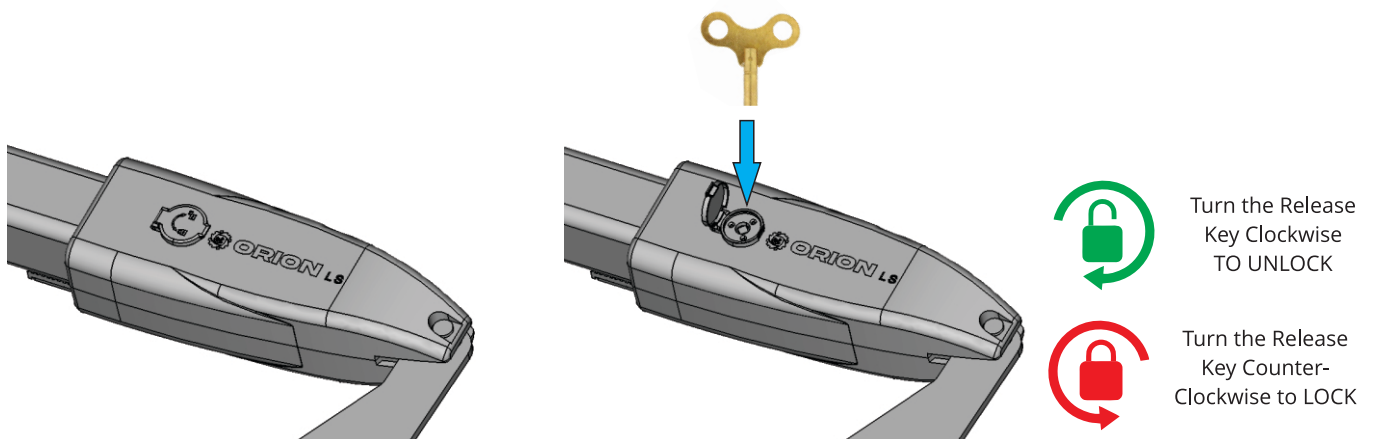

Installers Brief Checklist

- Ensure the gate(s) structure is rigid and does not flex
- Ensure you will be using an adequate fastening system to suit the structure and environment
- Ensure the gate(s) move freely and uniformly
- Ensure that a gate stop has/will be installed
- Ensure that the installation geometry can be adhered to
- Ensure that if any underground work is occurring you have followed the local regulations and checked with utilities providers
- Ensure the correct operator is to be installed based on size, weight, geometry and wind resistance
- Never supply mains power to a gate motor directly
- Never install if it will present a hazard or danger

Gate Stop and Actuator Placement

A Gate stop is MANDATORY to be installed as it will serve TWO purposes. Firstly it prevent the gate from over swinging OR being Pulled/Pushed further past the closed point. Secondly it prevents damage to the actuator using a full expanded stroke.

Ideally the gate stop should be within 400mm of the actuators mounting, meaning for double swing gate the actuators should be within 400mm from the ground level as there is typically a ground stop and for single gates within 400mm UP/DOWN from actuators gate rail.

FOR GATES OPENING OUTWARDS (PUSH TO OPEN) A OPEN POSITION GATE STOP MUST BE INSTALLED

Double Swing Gate Example

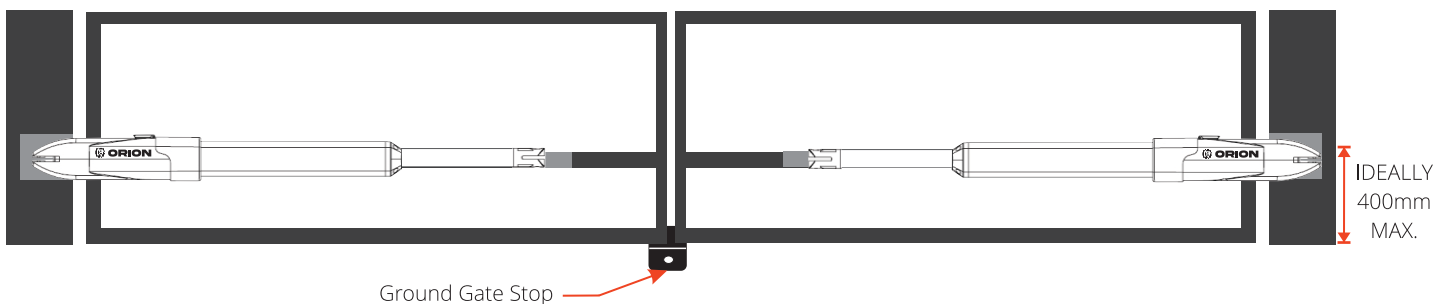

Post Gate Stop

Single Swing Gate Example

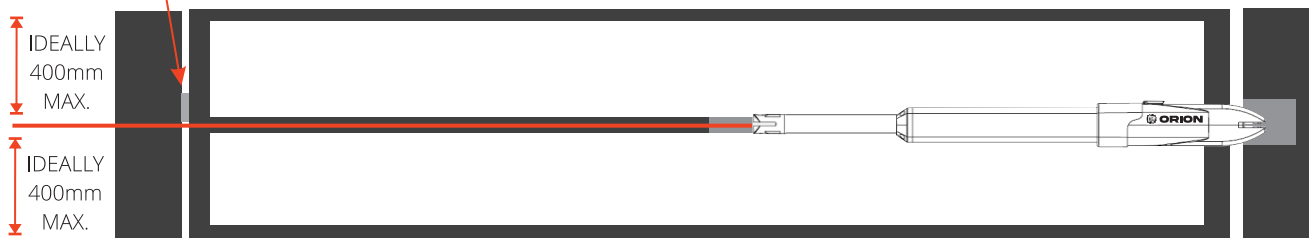

Bracket Measurements

Post Extender Plate

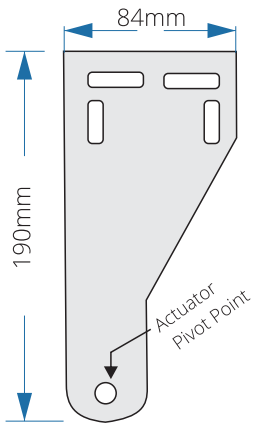

Assembly Bracket

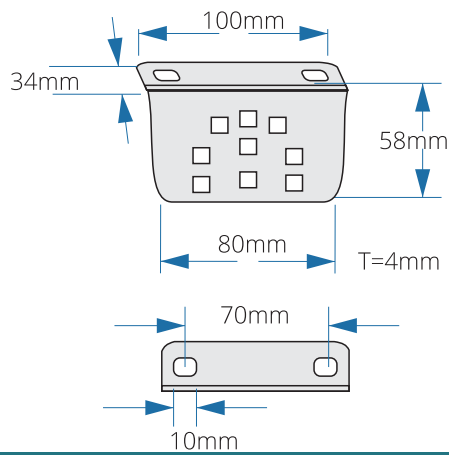

Gate Extender Plate

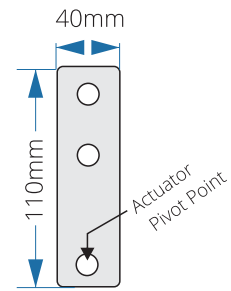

Bracket Assembly

Post Assembly

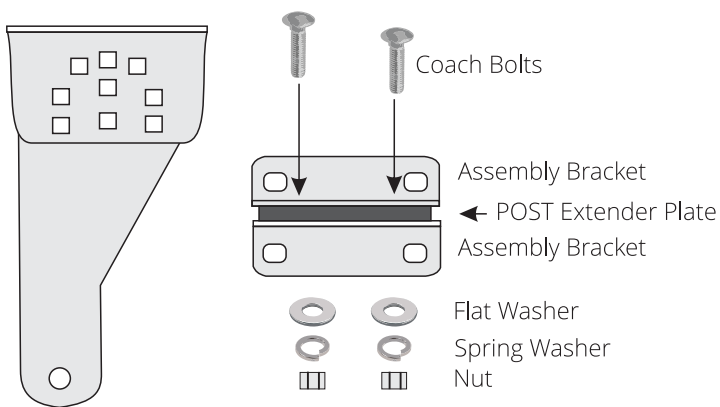

Gate Assembly

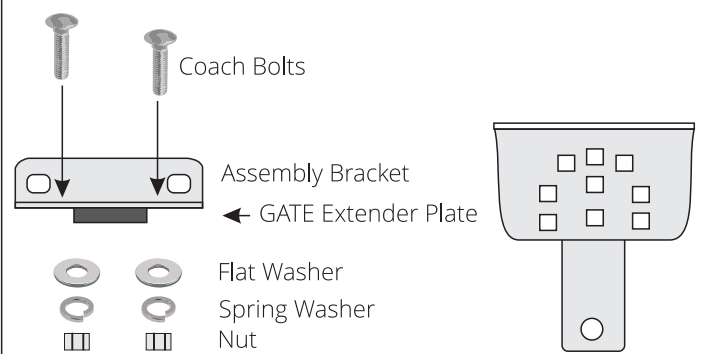

Post Bracket Manipulation

Up to 75mm can be cut away from the post bracket to help achieve the pivot geometry.

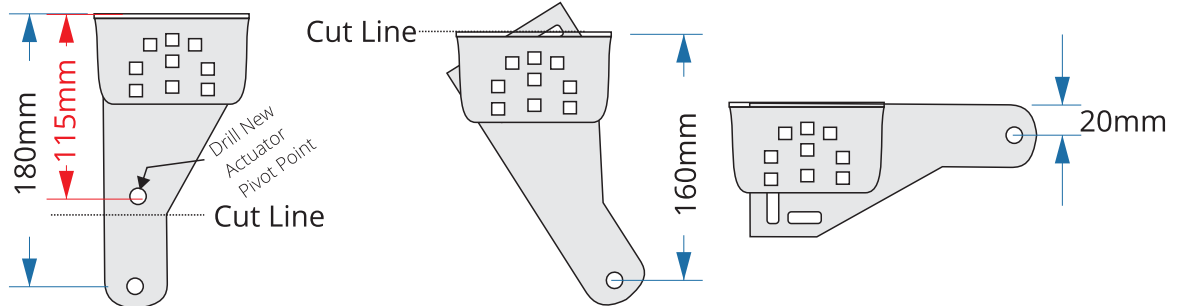

Round Timber Posts

Cut a Niche to allow for a flat installation surface. Use Coach Bolt or Coach Screws for Fixing

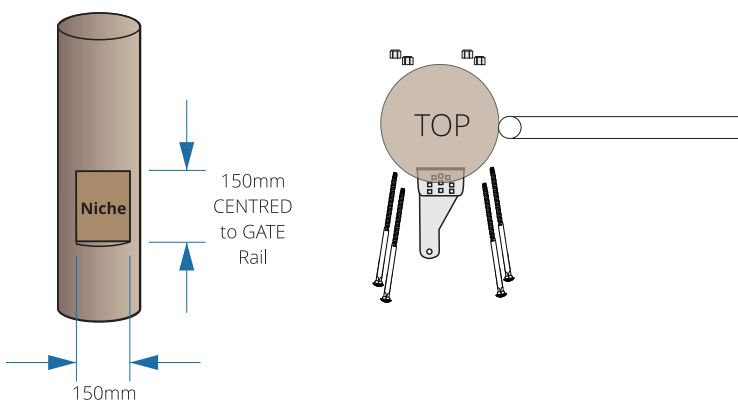

Farm Gates

Drill Holes according to correct placement of gate bracket. Use bolts and nut to install to the gate

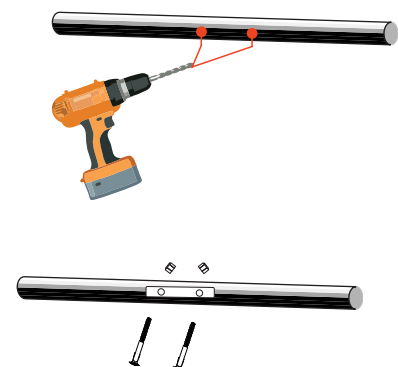

Pull To Open Installation (Gate opens TOWARDS the motor)

Step 1

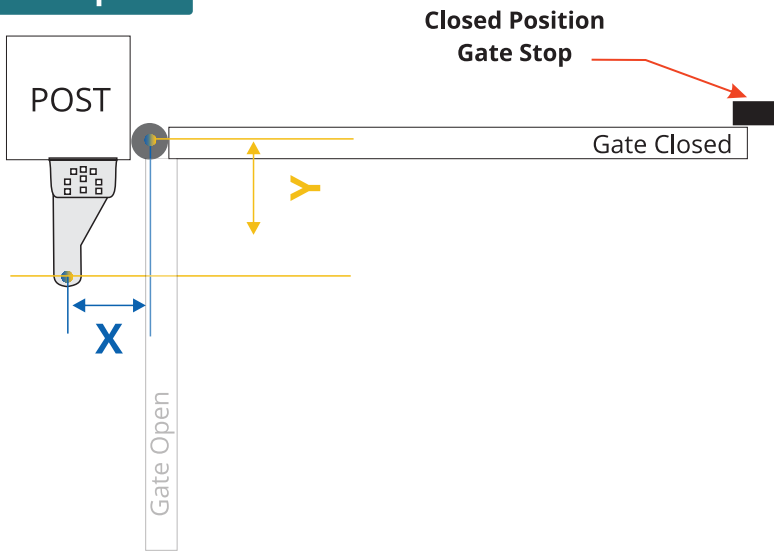

Adhere to the X and Y Geometry range

The post bracket can be adjusted to reach the best Y measurement or cut to a shorter length if required.

All measurements are made from the centre of the pivot hole to the centre of the hinge.

X = 90mm Min. (90°)/110mm Min. (100°) - Up to 130mm Max

Y = 140mm - 200mm

Step 2

- A. Assemble the POST bracket.
- B. Draw a centre line from the gate rail to the post.
- C. Install the actuator POST bracket to the post or wall according to the appropriate geometry WHILST Centred to the gate rail.

Adjust the bracket or cut the excess of the bracket now if necessary.

Plate Centre

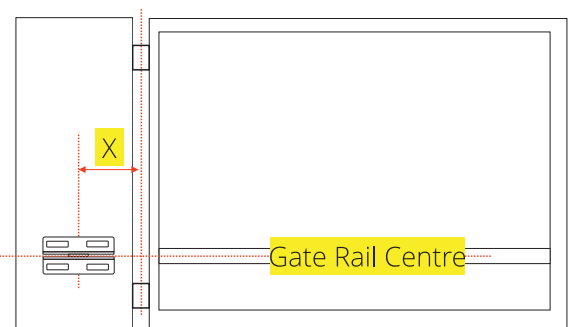

Gate Rail Centre

Step 3

COMPLETELY Open the gate to the installation OPEN position (90°-100°) based on the requirement and geometry installation.

MEASURE from the **post bracket pivot point** to the gate face diagonally and mark the position at **950mm** this is the centre point of the gate bracket.

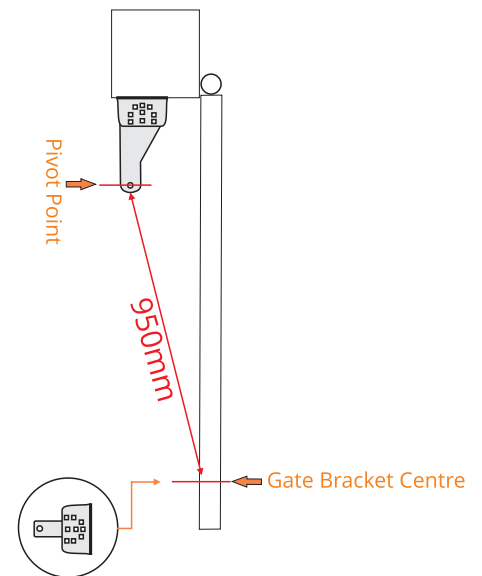

Step 4

Assemble then install the gate bracket to the post using the appropriate fasteners. Ensure the CENTRE of the brackets are level to one another.

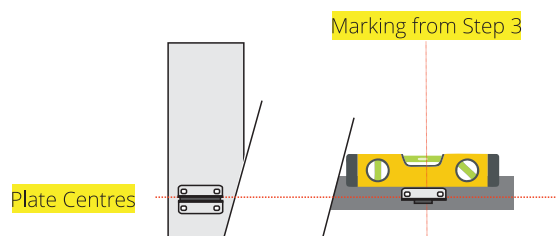
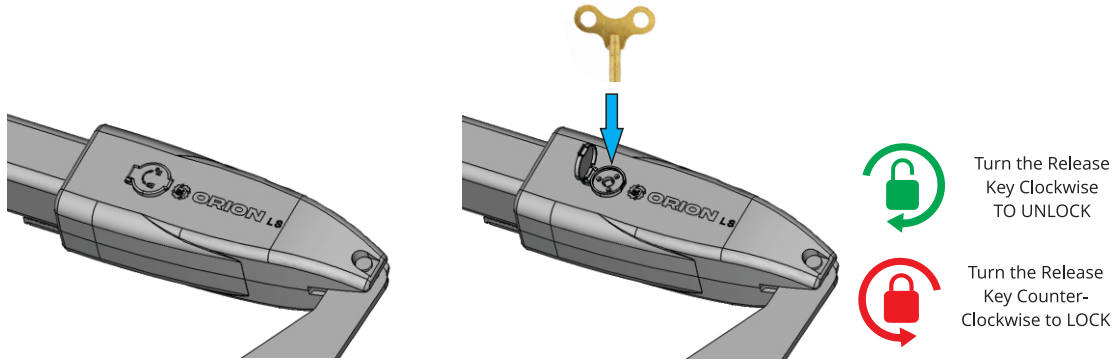

Plate Centres

Marking from Step 3

Step 5

Set the actuator to manual release (unlock) to prepare for the following steps.



Step 6

Slide the actuator on to the post and gate brackets, the gate position does not matter.

The manual release feature (unlocked) can now be used to allow expansion/retraction of the actuator if required. Fix in place using the supplied drop in pivot pins then secure with the split pin from the underside.

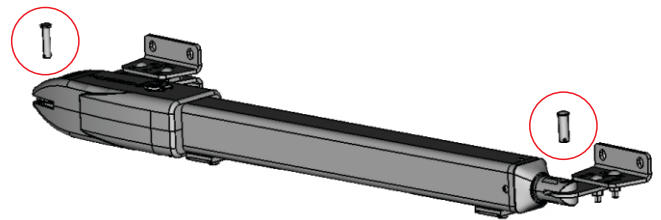

Step 7

Adjust the open position Limit stop by manually opening the gate to the maximum open angle (90°-100°).

Loosen (but do not remove) the limit stop screw.

Now slide the Limit Stop against the pistons end.

Tighten the screw to secure the stop point.

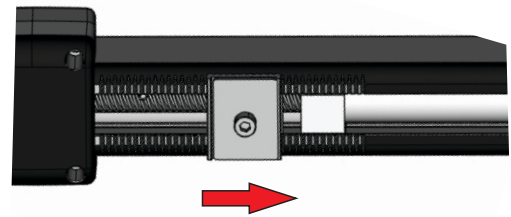

Step 8

If a ground stop for the closed position is to be used this step can be skipped. Ultimately using a ground stop provides the best hold over the gate when closed.

Adjust the close position Limit stop by manually closing the gate to the closed stop.

Loosen (but do not remove) the limit stop screw.

Now slide the Limit Stop against the pistons end.

Tighten the screw to secure the stop point.

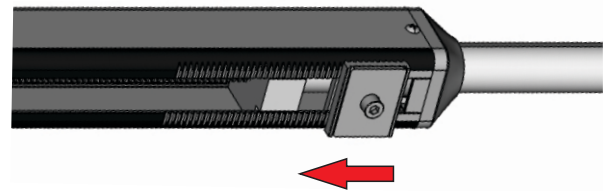

Step 9

Whilst still in manual release SLOWLY push and pull the gate and ensure the gate, actuator and brackets do not touch one another. The actuator should be able to move through the motion easily and should not bind.

Once complete re-engage (lock) the actuator in the OPEN position.

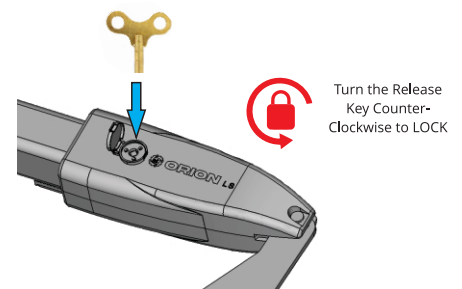

Step 10

Follow the illustration bellow for the connection to the Premier 24 Swing Gate Controller paying attention to the **Motor 2 connection being the master gate** and Motor 1 Connection being the Second Motor for Double Gates.

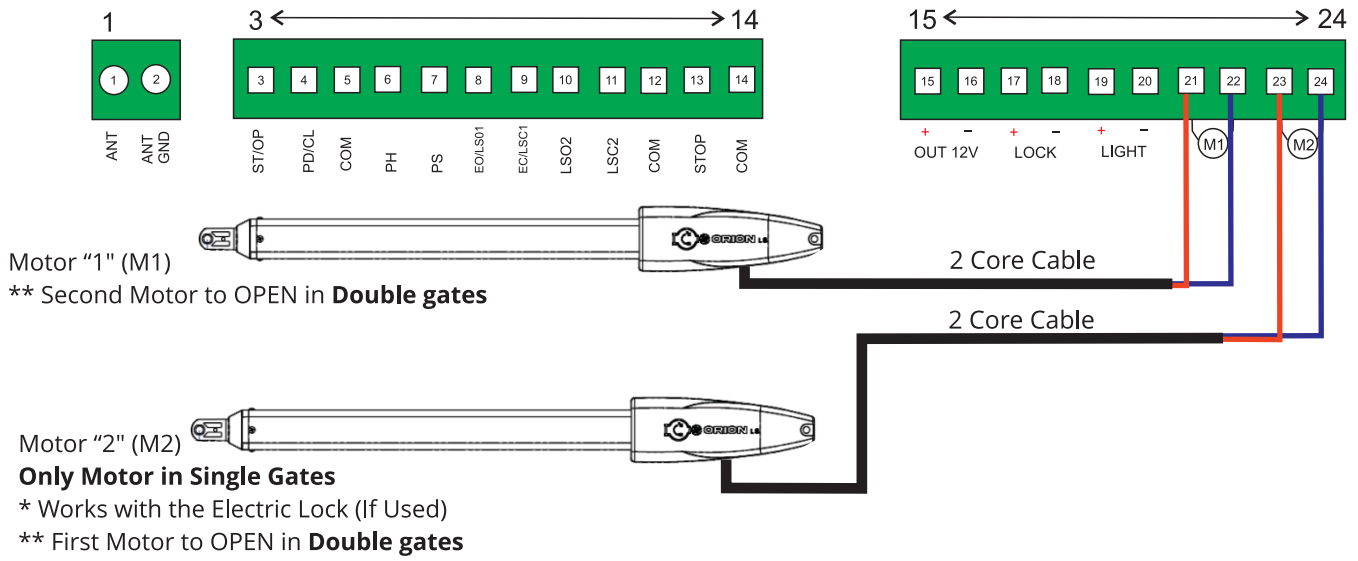

Step 11

Follow the Premier SW24 Instructions for setting the control board with series limit to be defined as (NT). Furthermore if required set the system to single gate if only one motor unit is in use (YS). These settings are all located in the advanced menu of the control board.

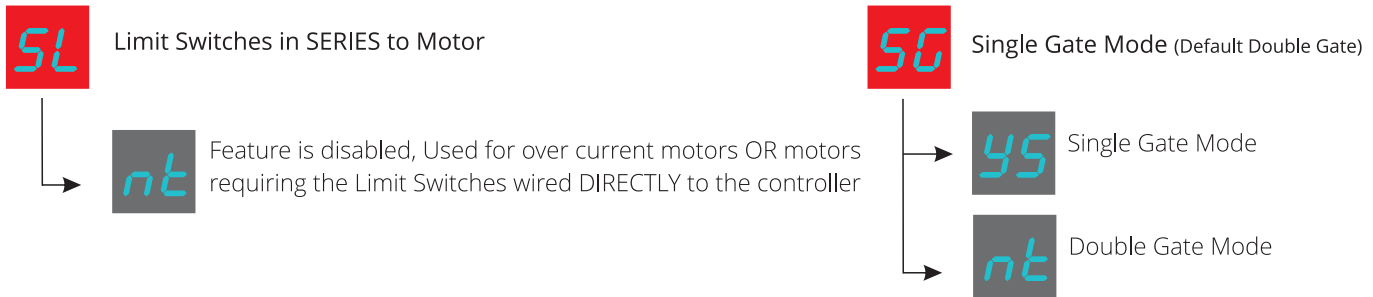

Step 12

Run the motor test mode for each gate through the Premier SW24 Control board to ensure each gate opens to its limit switch and also its closed position limit switch, make any necessary changes now to the limit strikers if required.

Page 19 of Premier SW24 manual

Step 13

With the gate(s) in the full open position activate the Learn time calibration to enable the controller to learn the distances of each gates operation.

Page 20 of Premier SW24 manual for Double Swing Gates

Page 21 of Premier SW24 manual for Single Swing Gates

Push To Open Installation (Gate opens AWAY from the motor)

Step 1

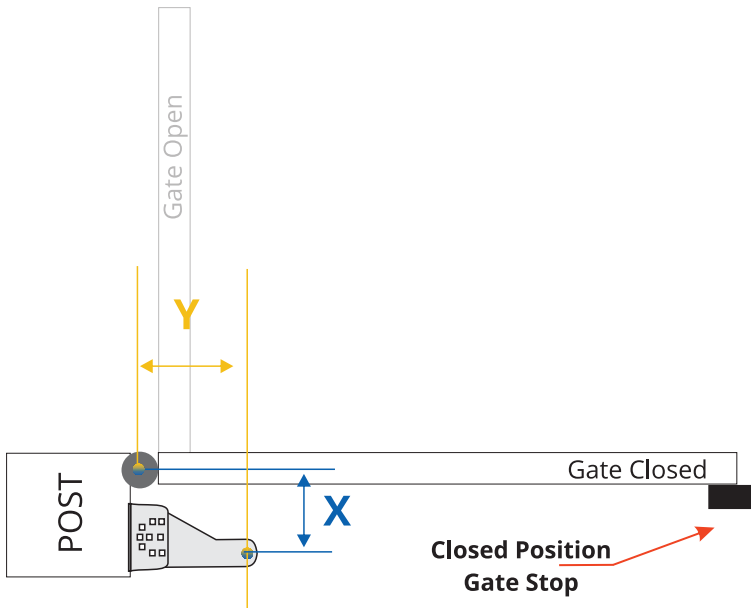

Adhere to the X and Y Geometry range

The post bracket can be adjusted to reach the best Y measurement or cut to a shorter length if required.

All measurements are made from the centre of the pivot hole to the centre of the hinge.

X = 90mm Min. (90°)/110mm Min. (100°) - Up to 130mm Max

Y = 140mm - 200mm

Step 2

- A. Assemble the POST bracket.
- B. Draw a centre line from the gate rail to the post.
- C. Install the actuator POST bracket to the post or wall according to the appropriate geometry WHILST Centred to the gate rail.

Adjust the bracket or cut the excess of the bracket now if necessary.

Plate Centre

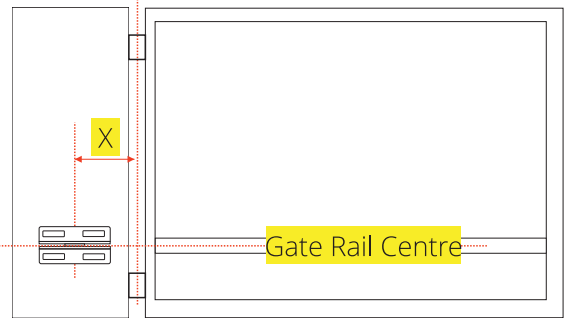

Step 3

COMPLETELY Close the gate to the installation Close Point.

MEASURE from the **post bracket pivot point** to the gate face diagonally and mark the position at **950mm** this is the centre point of the gate bracket.

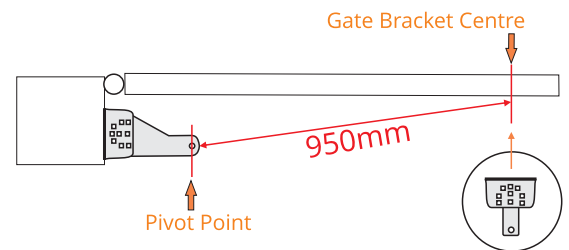

Step 4

Assemble then install the gate bracket to the post using the appropriate fasteners. Ensure the CENTRE of the brackets are level to one another.

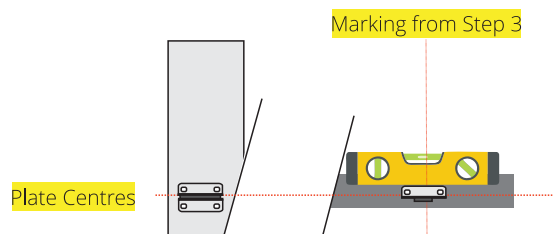

Step 5

Set the actuator to manual release (unlock) to prepare for the following steps.

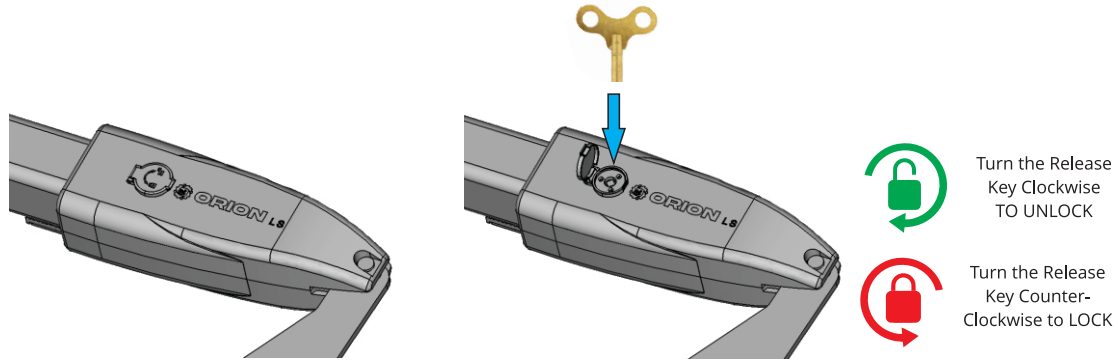

Step 6

Slide the actuator on to the post and gate brackets, the gate position does not matter.

The manual release feature (unlocked) can now be used to allow expansion/retraction of the actuator if required. Fix in place using the supplied drop in pivot pins then secure with the split pin from the underside.

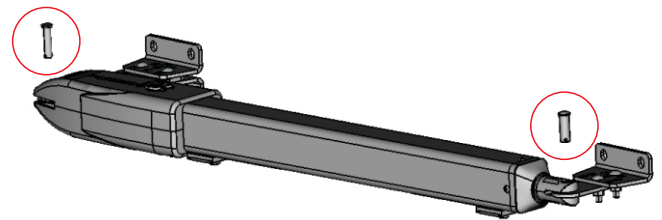

Step 7

If a ground stop for the closed position is to be used this step can be skipped. Ultimately using a ground stop provides the best hold over the gate when closed.

Adjust the close position Limit stop by manually closing the gate to the closed stop.

Loosen (but do not remove) the limit stop screw.

Now slide the Limit Stop against the pistons end.

Tighten the screw to secure the stop point.

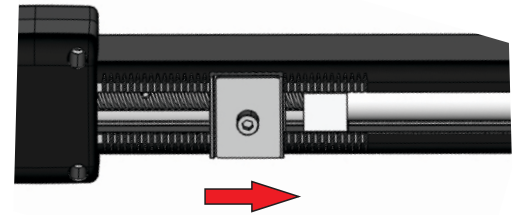

Step 8

Adjust the open position Limit stop by manually opening the gate to the maximum open angle (90°-100°).

Loosen (but do not remove) the limit stop screw.

Now slide the Limit Stop against the pistons end.

Tighten the screw to secure the stop point.

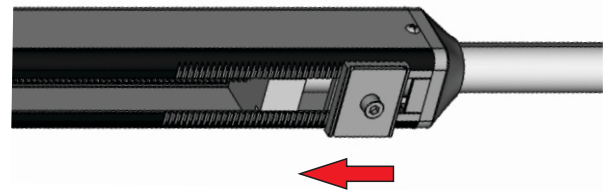

Step 9

Whilst still in manual release SLOWLY push and pull the gate and ensure the gate, actuator and brackets do not touch one another. The actuator should be able to move through the motion easily and should not bind.

Once complete re-engage (lock) the actuator in the OPEN position.

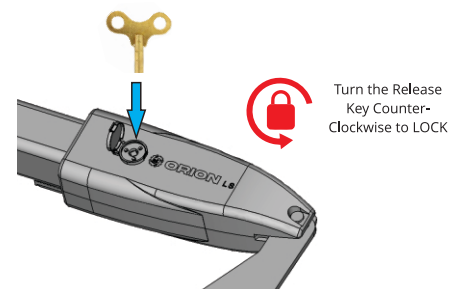

cont. Push To Open Installation (Gate opens AWAY from the motor)

Step 10

Follow the illustration bellow for the connection to the Premier 24 Swing Gate Controller paying attention to the **Motor 2 connection being the master gate** and Motor 1 Connection being the Second Motor for Double Gates.

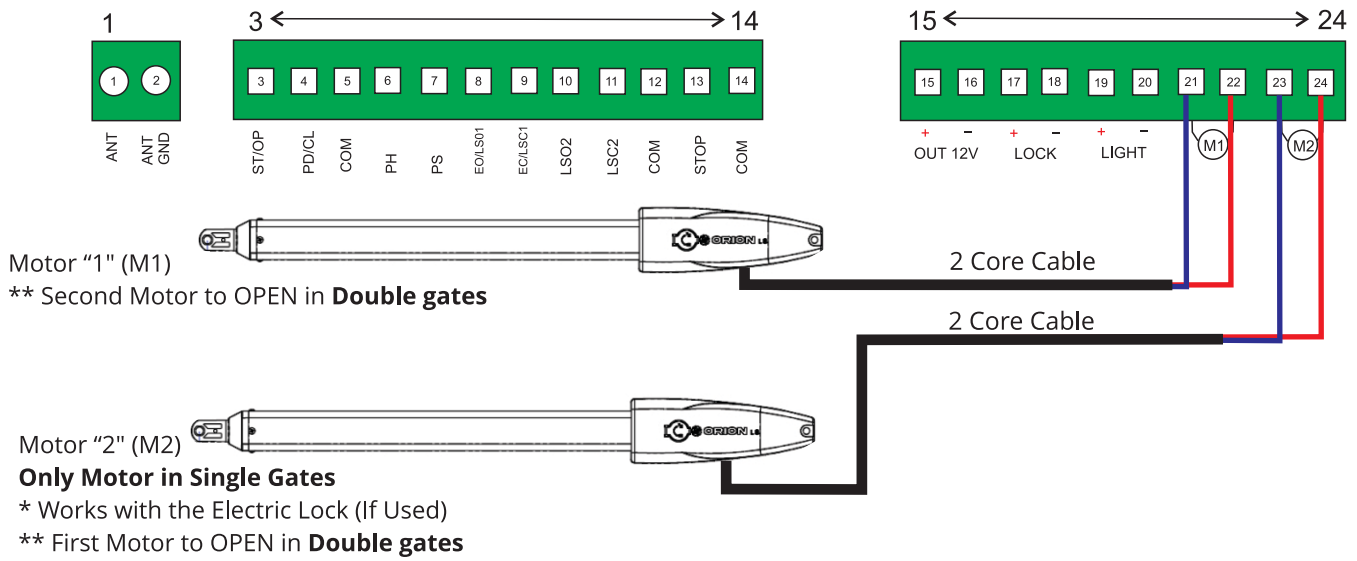

Step 11

Follow the Premier SW24 Instructions for setting the control board with series limit to be defined as (NT). Furthermore if required set the system to single gate if only one motor unit is in use (YS). These settings are all located in the advanced menu of the control board.

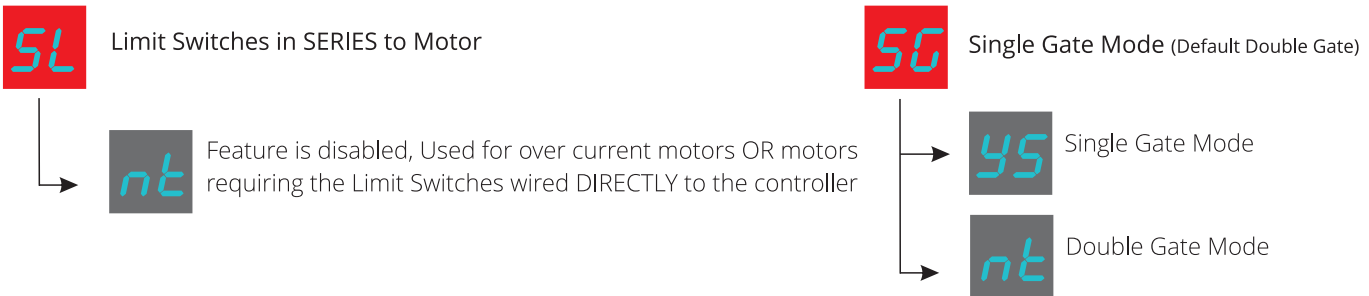

Step 12

Run the motor test mode for each gate through the Premier SW24 Control board to ensure each gate opens to its limit switch and also its closed position limit switch, make any necessary changes now to the limit strikers if required.

Page 19 of Premier SW24 manual

Step 13

With the gate(s) in the full open position activate the Learn time calibration to enable the controller to learn the distances of each gates operation.

Page 20 of Premier SW24 manual for Double Swing Gates

Page 21 of Premier SW24 manual for Single Swing Gates

Warranty Terms and Conditions

The product is warranted for a period of twelve months (one year) from the date of purchase, unless expressly specified as extended warranty (extension to the warranty period). The product is to be installed for its intended purpose and for normal use as outlined within the installation manual, the product warranty is exclusively for defects in manufacturing and manufacturing workmanship. It does not cover out of guidelines use, natural or other disasters, abnormal weather conditions, damage incurred in shipping or handling, damage caused by disaster such as fire, flood, wind, earthquake, lightning, excessive voltage, mechanical shock, water damage, damage caused by unauthorized attachment, alterations, modifications, or foreign objects, damage caused by peripherals (unless such peripherals were supplied by Automation Systems Australia), defects caused by failure to provide a suitable installation environment for the products, damage caused by usage of the products for purpose other than those for which it was designed, damage from improper maintenance, damage arising out of any other abuse, mishandling, and improper application of the products.

At its discretion Automation Systems Australia will require the item determined by the support staff to be returned to base in its original unmodified condition for a warranty inspection if within the warranty period. A return authorization "RA" number will be provided to be enclosed with the product in question. The warranty will not cover freight fees to base, customs fees or any labour costs at the installation site but will cover repair or replacement of the product as seen fit. Automation Systems Australia will cover the freight of the returned item to the original address if deemed as a warranty repair or replacement item. Any warranty repairs or replacements continue to carry through the remaining warranty period and do not extend or restart the period.

Under no circumstances shall Automation Systems Australia be liable for any special, incidental, or consequential damages based upon breach of warranty, breach of contract, negligence, strict liability, or any other legal theory. Such damages include, loss of profits, loss of the product or any associated equipment, cost of capital, cost of substitute or replacement equipment, facilities or services, down time, purchaser's time, the claims of third parties, including customers, and injury to property.

This warranty contains the entire warranty and shall be in lieu of any and all other warranties, whether expressed or implied (including all implied warranties of merchantability or fitness for a particular purpose). And of all other obligations or purporting to act on its behalf to modify or to change this warranty, nor to assume for it any other warranty or liability concerning this product.

Automation Systems Australia will at its option repair or replace out-of-warranty products at a determined cost which are returned to its base according to the following conditions. Anyone returning goods to Automation Systems Australia must first obtain an authorization number. Automation Systems Australia will not accept any shipment whatsoever for which prior authorization has not been obtained. Products which Automation Systems Australia determines to be repairable will be repaired and returned. A set fee which Automation Systems Australia has been predetermined and which may be revised from time to time will be charged for each unit repaired. Products which Automation Systems Australia determines not repairable will be replaced by the nearest equivalent product available at that time. The current market price for the replacement product will be charged for each replacement unit.